

SFM-AT800-S

solukon



The SFM-AT800-S is compatible with every LPBF-printer on the market.

Depowdering system for automated powder removal of metal laser-melted parts

The SFM-AT800-S cleans metal laser melted parts within a sealed process chamber. Through programmable rotation of the parts along two endless rotating axes metal powder is also removed from complex voids and support structures.

The SFM-AT800-S is compatible with SPR-Pathfinder® software from serial number 1.

The software automatically calculates the ideal motion sequence for each part, which is then read and executed by the Solukon system so that the powder is removed residual-free.

Like all systems the SFM-AT800-S is based on the Solukon Smart Powder Recuperation Technology SPR®.

[solukon.de](https://www.solukon.de)

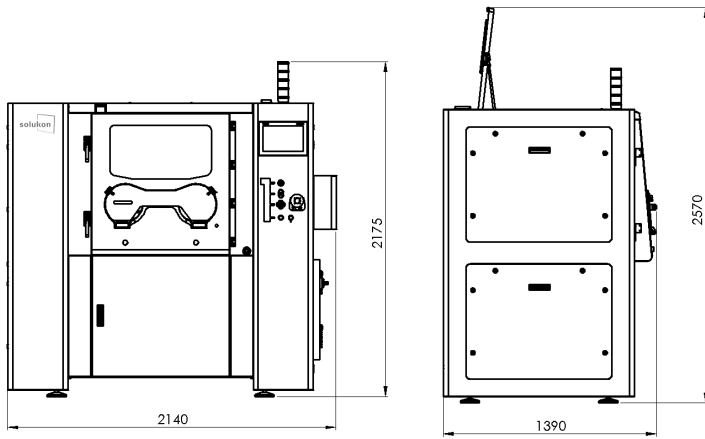
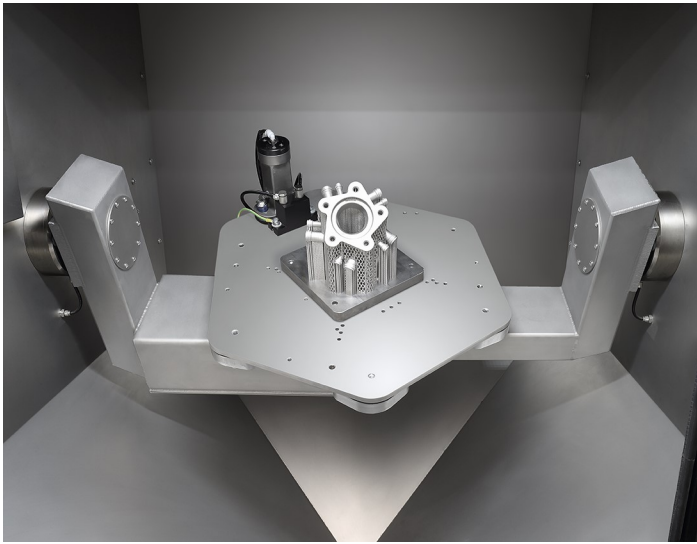

System specifications

Installation space (W x D x H)	3,500 x 2,500 x 3,000 mm
Weight	900 kg
Mains voltage / frequency	400 / 50 - 60 V / Hz
Power consumption	1.5 kW
Power supply	16 A

Compressed air specifications

Working pressure	6 bar
Consumption	max. 300 l/min

Inert gas specifications*

Working pressure	6 bar
Consumption	max. 300 l/min

* only with inert gas infusion option

Part spectrum

- material: aluminum-, steel-, titan- or copper alloy
- weight: up to 300 kg
- dimensions: up to 600 x 600 x 600 mm³
(or: 800 x 400 x 550 mm³)

Basic features

- automated 2-axis rotation device
- powder lock with special container
- vibration mechanism with wide frequency range
- glove ports for manual depowdering with compressed air or inert gas
- manual control via joystick

Options

- dust removal for non-reactive materials
- inert gas infusion for reactive materials (ATEX)
- direct connection to material processing
- top loading
- SPR-Pathfinder® software to calculate the ideal motion sequence
- programmable knocker
- Digital-Factory-Tool for quality assurance and automation integration
- OPC UA interface (ready for industry 4.0)

Advantages

- certified explosion protection
- high degree of protection from harmful dusts
- fast and economic part cleaning
- comfortable part handling
- qualifiable and reproducible cleaning results